



YEKTA TAHVIEH

Arvand

Arvand Liquid Chillers with Scroll Compressors & Brazen Plate Heat exchangers



17 standard models

**ASHPC
7.5 Thru 100 Tons
50 Hertz**

TABLE OF CONTENTS

	Page
Features of Arvand ASPHLC Chillers.....	1-3
Accessories.....	4
Model Number Nomenclature.....	5
Conversion Table.....	5
Refrigerant and Oils for Maneurop Scroll Compressors....	6
Physical Data.....	7
Cooler & Condenser Data.....	8
Performance Data.....	9-11
Electrical Data.....	12
Dimensions.....	13

conversion table

power	1000 kcal/hr = 1.17 kw 1000 kcal/hr = 3.96 Mbtuh 1000 kcal/hr = 0.33 TON	Temp	$T(k) = T(c) + 273.15$ $T(k) = T(R) / 1.8$ $T(k) = [T(f) + 459.67] / 1.8$ $T(c) = [T(f) - 32] / 1.8$
Density	1 kg /m ³ = .0624 Lb/ft ³		
Length	1m = 3.28 ft 1m = 39 in	Area	1 m ² = 10.76 ft ²
Mass	1 kg = 2.2 Lb 1 kg = .0685 slug	Velocity	1m/s = 3.3 ft /s
Pressuer	101.23 kpas = 1 atm 1 atm = 14.7 psi	Volume	1 lit/s = 15.8GPM
		flow rate	1 Lit/s = 2.16 fpm
		Volume	1 m ³ = 37.97ft ³
			1 m ³ = 264 GOL(USA)

ARVAND Water-Cooled Scroll Chillers 7.5 - 100 TON

YEKTA TAHVIEH ARVAND ASPHLC series liquid chillers are new products of this company. They are more compact and energy efficient by contrast to Reciprocating Liquid Chillers. This type of chiller uses Scroll compressors and Plate Heat Exchanger as Evaporator and Condenser .All units provide with **MANEUROP scroll compressors** and **SWEP Plate Heat Exchangers**. Units are one piece factory assembled packaged. Chillers cover a range of 7.5 to 100 ton. Disassembled delivery of all models is possible upon request.

Design theory:

The ARVAND control logic is to provide a full range of high efficient, reliable chillers applicable to many duties and built to conform to the requirements of energy saving and safety instructions. Factory or field installed options and accessories tailor the standard products to particular needs. In models 15-2 to 100-4 with dual circuits, one circuit continues to running while the other one is being serviced. It is very important in peak season and vital in many industrial cooling applications. This chiller produces low refrigeration tonnages with high efficiency and many privileges that are mentioned below:

High Efficiency:

Water-Cooled Scroll Chillers have EER coefficient about 3 at working with full capacity. Higher Efficiency (about 10%) is as a result of Scroll compressors and Plate Heat Exchangers. Since the hold-up volume of this type chiller is only a fraction of that In other technologies, the refrigerant charge may also be greatly reduced. With today's more expensive refrigerants mean big saving in installation and Operating costs.

Dimension Decrease:

Plate Heat Exchanger decreases dimensions and occupied space and causes easier Transportation.

Silent Performance:

Scroll compressors work silently and calmly by contrast to Reciprocating Chillers.

Easy Using:

This chiller is not as complicated as Reciprocating Liquid Chillers and making Use of chiller is possible for every body.

Less Corrosion:

Using Plate Heat Exchanger decreases corrosion very much.

Long Life:

Scroll Compressors and Plate Heat Exchanger cause long comfortable performance.

All ASLCW units are run and tested under real life conditions to prove the “ARVAND” design logic.

Beside of standard models, for any especial application “ARVAND “could be able to Deign and build liquid chillers, such as brine chiller to -40 ° c brine temperature

Features of ASLCW Chillers :

All models use multiple hermetic scroll compressors and Plate heat exchangers.

In all models thermostat or step controllers:

▶ **Frame.**

Extrude Aluminum profile and galvanized steel frame protected with baked -Epoxy resin or electro powder coating on request. All sections joints by stainless steel screws and bolts.

▶ **Compressor.**

All units provide with Maneurop hermetic scroll compressors from 7.5 to 25 hp. All units are one piece factory assembled packaged with overload protection By a klaxon embedded in the motor winding and crankcase, where the Constructor provides it, installed on vibrations absorbing rubber.

▶ **Evaporator.**

In AISI 316 stainless steel braze welded plates type. The Evaporator is Insulated with flexible closed cells material.

▶ **Condenser.**

In AISI 316 stainless steel braze welded plates type. True Dual models Used for dual circuits chillers.

▶ **Controller start and stop the compressors to ensure least power usage as the load Change.**

▶ **A shift switch changes the compressor starting sequence in order to balance the Operating hours of compressors.**

▶ **Over current protection devices in all three phases protect the compressors, they Trip manually, reset circuit breakers.**

▶ **Built in sub cooled in lower part of water cooled condenser, increase energy Efficiency.**

▶ **Crank case heaters prevent liquid refrigerant from accumulating in the compressors When the unit is shut down.**

- ▶ Liquid line sight glass that indicate quantity and wetness of refrigerant in liquid line.
- ▶ Control panel that enable the operator to control and diagnoses malfunction of all Controllers and compressors with thermometer to indicate inlet and outlet chilled Water temperature.
- ▶ Anti freeze protection that protects the evaporator from freezing.
- ▶ 3 Phase control to protect unit that install on input main power .That operates in Low or over voltage time.

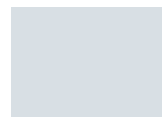

ACCESSORIES:

- ▶ Water flow switch that shut down unit if the cooling water flow is interrupted.
- ▶ 3 Phase control for protecting each compressor.
- ▶ Sound reducing enclosure.
- ▶ Main powers switch on electric board.
- ▶ Earthing circuits with shims and especial wiring and copper woven, wire cable.
- ▶ Accumulator in suction line to prevent liquid refrigerant enter to compressors.
- ▶ Controller start and stop the compressors to ensure least power usage as the load Change.
- ▶ A shift switch changes the compressor starting sequence in order to balance the Operating hours of compressors.
- ▶ Over current protection devices in all three phases protect the compressors, they Trip manually, reset circuit breakers.



**TRUE DUAL MODELS AS EVAPORATOR AND
CONDENSER FOR TWO CIRCUIT CHILLERS**

Model Number Nomenclature

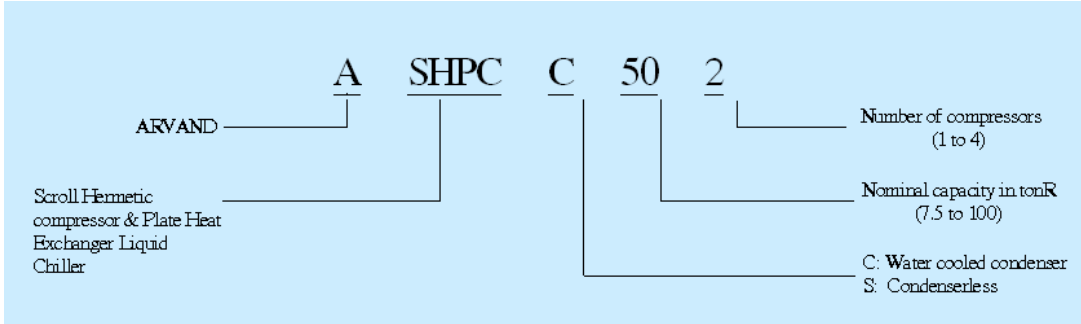

Conversion Table

power	1000 kcal/hr = 1.17 kw 1000 kcal/hr = 3.96 Mbtuh 1000 kcal/hr = 0.33 TON	Temp	$T(k) = T(c) + 273.15$ $T(k) = T(R) / 1.8$ $T(k) = [T(f) + 459.67] / 1.8$
Density	1 kg /m ³ = .0624 Lb/ft ³		$T(c) = [T(f) - 32] / 1.8$
Length	1m = 3.28 ft	Area	1 m ² = 10.76 ft ²
	1m = 39 in	Velocity	1m/s = 3.3 ft /s
Mass	1 kg = 2.2 Lb	Volume	1 lit/s = 15.8 GPM
	1 kg = .0685 slug	flow rate	1 Lit/s = 2.16 fpm
Pressure	101.23 kpas = 1 atm	Volume	1 m ³ = 37.97 ft ³
	1 atm = 14.7 psi		1 m ³ = 264 GAL(USA)

Refrigerant and oils for Maneurop scroll compressors

The introduction of HFC/POE systems has led to confusion as to what refrigerant and oils are approved for used in compressors.

Two types of lubricants are used: mineral oil for HCFC and P.O.E(poly ester) oil For HFC group of refrigerant.

Refrigerant	Oil type	Oil name
HCFC(R22)	Mineral	160P
HFC(R407c,R134a,R404)	P.O.E	160SZ

Always use the original Maneurop oil.it advisable to use oil from new cans only. This is mandatory for P.O.E oil due to its strong hygroscopic property. The oil In partly-used cans absorb moisture during storage. The can should only be opened Just before using the oil.

- Note:**
1. The Maneurop p.o.e. lubricant 160SZ is free from additives.
 2. The use of non-approved refrigerant may be dangerous and will void the Warranty.
 3. Using the wrong type or weight of oil for the refrigerant selected will void The warranty
 4. Contact the Yekta Tahviah Arvand engineering department before using any Refrigerant or oil not listed.
 5. All HFC/POE applications require a crankcase heater.
 6. Moisture must be kept below 50 ppm for POE oils.

Correction factor for new refrigeration(HFC)Application

Item	R22	R407c	R404a	R134
TC	1	0.94	1.07	0.64
THR	1	0.97	1.1	0.64
KW	1	1.05	1.15	0.64

Corrected TC= TC (from rating table) × correction factor

Corrected THR=THR (from rating table) × correction factor

Corrected KW=KW (from rating table) × correction factor

Physical Data

Model 7.5-1 to 30-2

Model	ASHPC	7.5-1	10-1	15-1	20-1	25-1	15-2	20-2	30-2
Nominal capacity water cooled	1000 * kcal/hr	16.7	23.2	34.9	47.1	60.2	33.4	46.4	69.8
	1000 * Btu/hr	66.1	91.9	138.2	186.5	238.4	132.3	183.7	276.4
Compressors	Circuit 1	1* 7.5	1 * 10	1*15	1*20	1*25	1* 7.5	1 * 10	1*15
	Circuit 2						1* 7.5	1 * 10	1*15
Cooler Model		Braze plate heat exchanger made by SS316							
Condenser Model		Braze plate heat exchanger made by SS316							
Refrigerant	Circuit 1 (kg)	5.3	7	10.6	14	17.6	5.3	7	10.6
Charge	Circuit 2 (kg)						5.3	7	10.6
Shipping weight	(kg)	370	370	380	390	400	510	510	520
Capacity	No.control steps	1	1	1	1	1	2	2	2

Physical Data

Model 35-2 to 100-4

Model	ASHPC	35-2	40-2	45-2	50-2	60-4	70-4	80-4	90-4	100-4
Nominal capacity water cooled	1000 * kcal/hr	88.4	101.6	116	130.4	150.4	176.8	201.6	232	260.8
	1000 * Btu/hr	350.1	402.3	459.4	516.4	595.6	700.1	798.3	918.7	1032.8
Compressors	Circuit 1	1*20	1*20	1*25	1*25	2*15	1*20	2*20	1*20	2*25
	Circuit 2	1*15	1*20	1*20	1*25	2*15	1*20	2*20	1*20	2*25
Cooler Model		Braze plate heat exchanger made by SS316								
Condenser Model		Braze plate heat exchanger made by SS316								
Refrigerant	Circuit 1 (kg)	14	14	17.6	17.6	10.6	24.6	14	31.6	35.2
Charge	Circuit 2 (kg)	10.6	14	14	17.6	10.6	24.6	14	31.6	35.2
Shipping weight	(kg)	530	550	580	600	700	790	1150	1180	1230
Capacity	No.control steps	2	2	2	2	4	4	4	4	4

Rating are based on leaving water temp 7 ° c , condenser entering water temp.35 ° c & leaving at40 ° c

Cooler Data(Brazed plate type)

Model 7.5-1 to 30-2

Model	ASHPC	7.5-1	10-1	15-1	20-1	25-1	15-2	20-2	30-2
Cooling surface(m ²)		1.65	2.48	4.01	5.13	6.48	3.61	4.68	6.76
No.of refrigerant circuits		1	1	1	1	1	2	2	2
Connections		AG	AG	AG	AG	AG	AG	AG	AG
Water in & out		1 1/4"	1 1/4"	1 1/4"	2"	2"	2 1/2"	2 1/2"	2 1/2"

Cooler Data(Brazed plate type)

Model 35-2 to 100-4

Model	ASHPC	35-2	40-2	45-2	50-2	60-4	70-4	80-4	90-4	100-4
Cooling surface(m ²)		8.84	8.84			14.04	16.64	19.76	23.4	28.08
No.of refrigerant circuits		2	2	2	2	2	2	2	2	2
Connections		AG	AG	AG	AG	AG	DN	DN	DN	DN
Water in & out		2 1/2"	2 1/2"	2 1/2"	2 1/2"	2 1/2"	65	65	65	65

Condenser Data(Brazed plate type)

Model 7.5-1 to 30-2

Model	ASHPC	7.5-1	10-1	15-1	20-1	25-1	15-2	20-2	25-2
Cooling surface(m ²)		1.65	2.24	4.01	5.13	6.48	4.16	5.2	7.8
No.of refrigerant circuits		1	1	1	1	1	2	2	2
Connections		AG	AG	AG	AG	AG	AG	AG	AG
Water in & out		1 1/4"	1 1/4"	1 1/4"	2"	2"	2 1/2"	2 1/2"	2 1/2"

Condenser Data(Brazed plate type)

Model 35-2 to 100-4

Model	ASHPC	35-2	40-2	45-2	50-2	60-4	70-4	80-4	90-4	100-4
Cooling surface(m ²)				13.52	13.52	15.6	19.76	24.96	37.44	46.02
No.of refrigerant circuits		2	2	2	2	2	2	2	2	2
Connections		AG	AG	AG	AG	DN	DN	DN	DN	DN
Water in & out		2 1/2"	2 1/2"	2 1/2"	2 1/2"	65	65	65	85	85

PERFORMANCE DATA:

WATER COOLED (5°c LEAVING CHILLED WATER TEMP)

27° c Condenser Entering Water Temp .

30° c Condenser Entering Water Temp .

32° c Condenser Leaving Water Temp .

35°c Condenser Leaving Water Temp .

UNIT SIZE	CAP 1000 Kcal / hr	K W	THR 1000 Kcal / hr	COOLER		CONDENSER		UNIT SIZE	CAP 1000 Kcal / hr	K W	THR 1000 Kcal / hr	COOLER		CONDENSER	
				Flow Lit / sec	PD m H2O	Flow Lit / sec	PD m H2O					Flow Lit / sec	PD m H2O	Flow Lit / sec	PD m H2O
7.5-1	17.4	4.6	21.3	1.0	2.8	1.2	4.7	7.5-1	16.9	4.9	21.1	0.9	2.7	1.2	4.6
10-1	24.2	6.2	29.5	1.3	3.0	1.6	5.2	10-1	23.5	6.6	29.2	1.3	2.9	1.6	5.1
15-1	36.2	9.5	44.4	2.0	3.2	2.5	4.2	15-1	35.3	10.1	44.0	2.0	3.1	2.4	4.1
20-1	49	12.9	60.1	2.7	3.5	3.3	4.7	20-1	47.7	13.6	59.4	2.6	3.3	3.3	4.5
25-1	62.8	16.2	76.7	3.5	2.9	4.3	5.3	25-1	61	17.1	75.7	3.4	2.8	4.2	5.1
15-2	34.8	9.2	42.7	1.9	1.5	2.4	3.8	15-2	33.8	9.8	42.2	1.9	1.4	2.3	3.7
20-2	48.4	12.2	58.9	2.7	1.5	3.3	4.0	20-2	47	13.2	58.4	2.6	1.4	3.2	3.9
30-2	72.4	19.0	88.8	4.0	2.1	4.9	4.6	30-2	70.6	20.2	88.0	3.9	2.0	4.9	4.5
35-2	85.2	22.5	104.6	4.7	1.9	5.8	3.6	35-2	83	23.7	103.4	4.6	1.8	5.7	3.5
40-2	98	25.8	120.2	5.4	2.5	6.7	4.7	40-2	95.4	27.2	118.8	5.3	2.4	6.6	4.6
45-2	111.8	43.9	149.6	6.2	2.7	8.3	4.5	45-2	108.7	30.7	135.1	6.0	2.6	7.5	3.7
50-2	125.6	62.0	179.0	6.9	3.4	9.9	6.4	50-2	122	34.2	151.4	6.7	3.2	8.4	4.6
60-4	144.8	38.0	177.5	8.0	3.3	9.9	4.8	60-4	141.2	40.4	176.0	7.8	3.1	9.8	4.8
70-4	170.4	44.8	209.0	9.4	3.7	11.6	5.2	70-4	166	47.4	206.8	9.2	3.4	11.5	5.0
80-4	196	51.6	240.4	10.8	3.6	13.4	5.1	80-4	190.8	54.4	237.6	10.6	3.4	13.2	5.0
90-4	223.6	87.8	299.2	12.4	3.7	16.6	6.1	90-4	217.4	61.4	270.3	12.0	3.5	15.0	5.0
100-4	251.2	124.0	358.0	13.9	4.6	19.9	7.1	100-4	244	68.4	302.9	13.5	4.3	16.8	5.2

35° c Condenser Entering Water Temp .

40° c Condenser Entering Water Temp .

40° c Condenser Leaving Water Temp .

45°c Condenser Leaving Water Temp .

UNIT SIZE	CAP 1000 Kcal / hr	K W	THR 1000 Kcal / hr	COOLER		CONDENSER		UNIT SIZE	CAP 1000 Kcal / hr	K W	THR 1000 Kcal / hr	COOLER		CONDENSER	
				Flow Lit / sec	PD m H2O	Flow Lit / sec	PD m H2O					Flow Lit / sec	PD m H2O	Flow Lit / sec	PD m H2O
7.5-1	16.1	5.4	20.7	0.9	2.4	1.2	4.4	7.5-1	15.2	6.0	20.4	0.8	2.2	1.1	4.3
10-1	22.4	7.4	28.8	1.2	2.7	1.6	5.0	10-1	21.2	8.2	28.3	1.2	2.4	1.6	4.8
15-1	33.7	11.2	43.3	1.9	2.8	2.4	4.0	15-1	31.9	12.4	42.6	1.8	2.5	2.4	3.8
20-1	45.4	15.0	58.3	2.5	3.0	3.2	4.3	20-1	43	16.4	57.1	2.4	2.8	3.2	4.2
25-1	57.9	18.7	74.0	3.2	2.5	4.1	4.9	25-1	54.8	20.4	72.4	3.0	2.3	4.0	4.7
15-2	32.2	10.8	41.5	1.8	1.3	2.3	3.6	15-2	30.4	12.0	40.7	1.7	1.2	2.3	3.4
20-2	44.8	14.8	57.5	2.5	1.3	3.2	3.8	20-2	42.4	16.4	56.5	2.3	1.2	3.1	3.6
30-2	67.4	22.4	86.7	3.7	1.8	4.8	4.3	30-2	63.8	24.8	85.2	3.5	1.6	4.7	4.2
35-2	79.1	26.2	101.7	4.4	1.6	5.6	3.4	35-2	74.9	28.8	99.7	4.1	1.5	5.5	3.2
40-2	90.8	30.0	116.6	5.0	2.1	6.5	4.4	40-2	86	32.8	114.2	4.8	1.9	6.3	4.2
45-2	103.3	33.7	132.3	5.7	2.4	7.3	3.5	45-2	97.8	36.8	129.5	5.4	2.1	7.2	3.4
50-2	115.8	37.4	148.0	6.4	2.9	8.2	4.4	50-2	109.6	40.8	144.7	6.1	2.6	8.0	4.2
60-4	134.8	44.8	173.4	7.5	2.9	9.6	4.6	60-4	127.6	49.6	170.3	7.1	2.6	9.5	4.4
70-4	158.2	52.4	203.3	8.7	3.2	11.3	4.9	70-4	149.8	57.6	199.4	8.3	2.9	11.1	4.6
80-4	181.6	60.0	233.3	10.0	3.1	13.0	4.8	80-4	172	65.6	228.5	9.5	2.8	12.7	4.6
90-4	206.6	67.4	264.6	11.4	3.1	14.7	4.8	90-4	195.6	73.6	259.0	10.2	2.8	14.4	4.6
100-4	231.6	74.8	296.0	12.8	3.9	16.4	4.9	100-4	219.2	81.6	289.5	12.1	3.5	16.1	4.7

PERFORMANCE DATA:

WATER COOLED (6°c LEAVING CHILLED WATER TEMP)

27° c Condenser Entering Water Temp .

30° c Condenser Entering Water Temp .

32° c Condenser Leaving Water Temp .

35°c Condenser Leaving Water Temp .

UNIT SIZE	CAP 1000 Kcal / hr	K W	THR 1000 Kcal / hr	COOLER		CONDENSER		UNIT SIZE	CAP 1000 Kcal / hr	K W	THR 1000 Kcal / hr	COOLER		CONDENSER	
				Flow Lit / sec	PD m H2O	Flow Lit / sec	PD m H2O					Flow Lit / sec	PD m H2O	Flow Lit / sec	PD m H2O
7.5-1	17.7	4.6	21.7	1.0	2.9	1.2	4.9	7.5-1	17.2	4.9	21.4	1.0	2.7	1.2	4.7
10-1	24.6	6.2	29.9	1.4	2.3	1.7	5.4	10-1	23.9	6.6	29.6	1.1	2.1	1.6	5.3
15-1	36.9	9.5	45.1	1.7	2.4	2.5	4.4	15-1	36	10.1	44.7	1.7	2.3	2.5	4.2
20-1	49.9	12.9	61.0	2.3	2.6	3.4	4.8	20-1	48.6	13.7	60.4	2.2	2.5	3.4	4.7
25-1	64	16.3	78.0	3.0	2.2	4.3	5.5	25-1	62.2	17.1	76.9	2.9	2.1	4.3	5.3
15-2	35.4	9.2	43.3	1.6	1.1	2.4	3.9	15-2	34.4	9.8	42.8	1.6	1.1	2.4	3.8
20-2	49.2	12.4	59.9	2.3	1.1	3.3	4.1	20-2	47.8	12.1	58.2	2.2	1.0	3.2	3.9
30-2	73.8	19.0	90.2	3.4	1.5	5.0	4.7	30-2	72	20.2	89.4	3.3	1.5	5.0	4.6
35-2	86.8	22.4	106.1	4.0	1.4	5.9	3.7	35-2	84.6	23.8	105.1	3.9	1.3	5.8	3.6
40-2	99.8	25.8	122.0	4.6	1.8	6.8	4.8	40-2	97.2	27.4	120.8	4.5	1.7	6.7	4.7
45-2	113.9	29.2	139.0	5.3	2.0	7.7	3.9	45-2	110.8	30.8	137.3	5.1	1.9	7.6	3.8
50-2	128	32.6	156.1	5.9	2.5	8.7	4.9	50-2	124.4	34.2	153.8	5.7	2.4	8.5	4.7
60-4	147.6	38.0	180.3	6.8	2.4	10.0	5.0	60-4	144	40.4	178.8	6.6	2.3	9.9	4.9
70-4	173.6	44.8	212.2	8.0	2.7	11.8	5.3	70-4	169.2	47.6	210.2	7.8	2.5	11.7	5.2
80-4	199.6	51.6	244.0	9.2	2.6	13.6	5.3	80-4	194.4	54.8	241.6	9.0	2.5	13.4	5.1
90-4	227.8	58.4	278.1	10.5	2.7	15.5	5.3	90-4	221.6	61.6	274.6	10.2	2.5	15.3	5.2
100-4	256	65.2	312.1	11.8	3.3	17.3	5.5	100-4	248.8	68.4	307.7	11.5	3.2	17.1	5.3

35° c Condenser Entering Water Temp .

40° c Condenser Entering Water Temp .

40° c Condenser Leaving Water Temp .

45°c Condenser Leaving Water Temp .

UNIT SIZE	CAP 1000 Kcal / hr	K W	THR 1000 Kcal / hr	COOLER		CONDENSER		UNIT SIZE	CAP 1000 Kcal / hr	K W	THR 1000 Kcal / hr	COOLER		CONDENSER	
				Flow Lit / sec	PD m H2O	Flow Lit / sec	PD m H2O					Flow Lit / sec	PD m H2O	Flow Lit / sec	PD m H2O
7.5-1	16.4	5.4	21.0	0.9	2.5	1.2	4.5	7.5-1	15.5	6.0	20.7	0.9	2.3	1.2	4.4
10-1	22.8	7.3	29.1	1.1	2.0	1.6	5.1	10-1	21.5	8.2	28.6	1.0	1.8	1.6	4.9
15-1	34.3	11.2	43.9	1.6	2.1	2.4	4.1	15-1	32.5	12.4	43.2	1.5	1.9	2.4	4.0
20-1	46.2	15.0	59.1	2.1	2.2	3.3	4.5	20-1	43.8	16.5	58.0	2.0	2.0	3.2	4.3
25-1	59.1	18.7	75.2	2.7	1.9	4.2	5.0	25-1	55.8	20.5	73.4	2.6	1.7	4.1	4.8
15-2	32.8	10.8	42.1	1.5	1.0	2.3	3.7	15-2	31	12.0	41.3	1.4	0.9	2.3	3.5
20-2	45.6	14.6	58.2	2.1	1.0	3.2	3.8	20-2	43	16.4	57.1	2.0	0.9	3.2	3.7
30-2	68.6	22.4	87.9	3.2	1.3	4.9	4.5	30-2	65	24.8	86.4	3.0	1.2	4.8	4.3
35-2	80.5	26.2	103.1	3.7	1.2	5.7	3.5	35-2	76.3	28.9	101.2	3.5	1.1	5.6	3.3
40-2	92.4	30.0	118.2	4.3	1.6	6.6	4.5	40-2	87.6	33.0	116.0	4.0	1.4	6.4	4.3
45-2	105.3	33.7	134.3	4.9	1.7	7.5	3.6	45-2	99.6	37.0	131.5	4.6	1.6	7.3	3.5
50-2	118.2	37.4	150.4	5.5	2.1	8.4	4.5	50-2	111.6	41.0	146.9	5.5	2.1	8.2	4.3
60-4	137.2	44.8	175.8	6.3	2.1	9.8	4.7	60-4	130	49.6	172.7	6.0	1.9	9.6	4.6
70-4	161	54.4	207.8	7.4	2.3	11.5	5.1	70-4	152.6	57.8	202.4	7.0	2.1	11.2	4.8
80-4	184.8	60.0	236.5	8.5	2.3	13.1	4.9	80-4	175.2	66.0	232.0	8.1	2.0	12.9	4.7
90-4	210.6	67.4	268.6	9.7	2.3	14.9	4.9	90-4	199.2	74.0	262.9	9.2	2.1	14.6	4.7
100-4	236.4	74.8	300.8	10.9	2.9	16.7	5.1	100-4	223.2	82.0	293.8	10.3	2.6	16.3	4.8

PERFORMANCE DATA:

WATER COOLED (7°c LEAVING CHILLED WATER TEMP)

27° c Condenser Entering Water Temp .
32° c Condenser Leaving Water Temp .

30° c Condenser Entering Water Temp .
35° c Condenser Leaving Water Temp .

UNIT SIZE	CAP 1000 Kcal / hr	K W	THR 1000 Kcal / hr	COOLER		CONDENSER		UNIT SIZE	CAP 1000 Kcal / hr	K W	THR 1000 Kcal / hr	COOLER		CONDENSER	
				Flow Lit / sec	PD m H2O	Flow Lit / sec	PD m H2O					Flow Lit / sec	PD m H2O	Flow Lit / sec	PD m H2O
7.5-1	18.1	4.6	22.1	1.0	3.0	1.2	5.0	7.5-1	17.6	4.9	21.8	1.0	2.9	1.2	4.9
10-1	25.1	6.2	30.4	1.2	2.3	1.7	5.6	10-1	24.5	6.6	30.2	1.1	2.2	1.7	5.5
15-1	37.6	9.5	45.8	1.7	2.4	2.5	4.5	15-1	36.6	10.1	45.3	1.7	2.3	2.5	4.3
20-1	50.8	12.9	61.9	2.3	2.7	3.4	4.9	20-1	49.4	13.7	61.2	2.3	2.5	3.4	4.8
25-1	65.2	16.3	79.2	3.0	2.2	4.4	5.6	25-1	63.4	17.2	78.2	2.9	2.1	4.3	5.4
15-2	36.2	9.2	44.1	1.7	1.2	2.5	4.1	15-2	35.2	9.8	43.6	1.6	1.1	2.4	4.0
20-2	50.2	12.4	60.9	2.3	1.1	3.4	4.2	20-2	49	12.1	59.4	2.3	1.1	3.3	4.0
30-2	75.2	19.0	91.6	3.5	1.6	5.1	4.9	30-2	73.2	20.2	90.6	3.4	1.5	5.0	4.7
35-2	88.4	22.4	107.7	4.1	1.4	6.0	3.8	35-2	86	23.8	107.0	4.0	1.4	5.8	3.5
40-2	101.6	25.8	123.8	4.7	1.9	6.9	5.0	40-2	98.8	27.4	122.4	4.6	1.8	6.8	4.8
45-2	116	29.2	141.1	5.4	2.1	7.8	4.0	45-2	112.8	30.9	139.4	5.2	2.0	7.7	3.9
50-2	130.4	32.6	158.5	6.0	4.5	8.8	5.0	50-2	126.8	34.4	156.4	5.9	2.5	8.7	4.9
60-4	150.4	38.0	183.1	6.9	2.5	10.2	5.2	60-4	146.4	40.4	181.2	6.8	2.4	10.0	5.0
70-4	176.8	44.8	215.4	8.2	2.8	12.0	5.5	70-4	172	47.6	213.0	7.9	2.6	11.8	5.3
80-4	201.6	51.7	246.2	9.3	2.7	13.7	5.3	80-4	197.6	54.8	244.8	9.1	2.6	13.6	5.3
90-4	232	58.4	282.3	10.7	2.8	15.7	5.5	90-4	225.6	61.8	278.8	10.4	2.6	15.5	5.4
100-4	260.8	65.2	316.9	12.0	3.5	17.6	5.6	100-4	253.6	68.8	312.8	11.7	3.3	17.4	5.5

35° c Condenser Entering Water Temp .
40° c Condenser Leaving Water Temp .

40° c Condenser Entering Water Temp .
45° c Condenser Leaving Water Temp .

UNIT SIZE	CAP 1000 Kcal / hr	K W	THR 1000 Kcal / hr	COOLER		CONDENSER		UNIT SIZE	CAP 1000 Kcal / hr	K W	THR 1000 Kcal / hr	COOLER		CONDENSER	
				Flow Lit / sec	PD m H2O	Flow Lit / sec	PD m H2O					Flow Lit / sec	PD m H2O	Flow Lit / sec	PD m H2O
7.5-1	16.7	5.4	21.3	0.9	2.6	1.2	4.7	7.5-1	15.8	6.0	21.0	0.9	2.3	1.2	4.5
10-1	23.2	7.3	29.5	1.1	2.0	1.6	5.2	10-1	22	8.2	29.0	1.0	1.8	1.6	5.0
15-1	34.9	11.2	44.5	1.6	2.1	2.5	4.2	15-1	33.1	12.4	43.8	1.5	1.9	2.4	4.0
20-1	47.1	15.0	60.0	2.2	2.3	3.3	4.6	20-1	44.6	16.5	58.8	2.1	2.1	3.3	4.4
25-1	60.2	18.8	76.4	2.8	1.9	4.2	5.1	25-1	56.9	20.5	74.6	2.6	1.7	4.1	5.0
15-2	33.4	10.8	42.7	1.5	1.0	2.4	3.8	15-2	31.6	12.0	41.9	1.5	0.9	2.3	3.6
20-2	46.4	14.6	59.0	2.1	1.0	3.3	3.9	20-2	44	16.4	58.1	2.0	0.9	3.2	3.8
30-2	69.8	22.4	89.1	3.2	1.4	5.0	4.6	30-2	66.2	24.8	87.6	3.1	1.2	4.9	4.4
35-2	82	26.2	104.6	3.8	1.2	5.8	3.5	35-2	77.7	28.9	102.6	3.6	1.1	5.7	3.4
40-2	94.2	30.0	120.0	4.3	1.6	6.7	4.6	40-2	89.2	33.0	117.6	4.1	1.5	6.5	4.4
45-2	107.3	33.8	136.4	5.0	1.8	7.6	3.7	45-2	101.5	37.0	133.4	4.7	1.6	7.4	3.6
50-2	120.4	37.6	152.8	5.6	2.2	8.5	4.7	50-2	113.8	41.0	149.1	5.2	2.0	8.3	4.4
60-4	139.6	44.8	178.2	6.4	2.2	8.9	4.9	60-4	132.4	49.6	175.1	6.1	1.9	9.7	4.7
70-4	164	52.4	209.1	7.6	2.4	11.6	5.1	70-4	155.4	57.8	205.2	7.2	2.2	11.4	4.9
80-4	188.4	60.0	240.1	8.7	2.3	13.3	5.0	80-4	178.4	66.0	235.2	8.2	2.2	13.1	4.8
90-4	214.6	67.6	272.8	9.9	2.4	15.2	5.1	90-4	203	74.0	266.7	9.4	2.1	14.8	4.9
100-4	240.8	75.2	305.5	11.1	3.0	17.0	5.2	100-4	227.6	82.0	298.2	10.5	2.7	16.6	4.9

Electrical Data (50 Hz Network voltage(v) 380 - 400)

Model		WSA	MCC	Rec Fuse Amp	Max Fuse Amp
ASPHLC	7.5-1	15.1	17	18.15	27.2
	10-1	25.9	29	31.05	46.6
	15-1	36.2	35	43.5	65.2
	20-1	44.6	50	53.55	80.3
	25-1	61.6	69	73.95	110.9
	15-2	27.2	34	30.3	39.3
	20-2	46.6	58	51.8	67.3
	30-2	65.3	70	72.5	94.3
	35-2	73.6	85	82.6	109.3
	40-2	80.3	100	89	116
	45-2	97.3	119	109.7	146.6
	50-2	110.9	138	123.3	160.2
	60-4	123.2	140	130.5	152.2
	70-4	138.3	170	147.3	174
	80-4	151.7	200	160.7	187.4
	90-4	182.3	238	194.7	231.6
100-4	209.5	276	221.9	258.8	

Max kw : Maximum Power Input.
 WSA : Wire sizing amps per NEC ,section 430-24 to use the sum of 125% of the largest RLA plus 100% of other RLA s.
 MCC : Maximum compressor current
 Rec Fuse Amp :150% of the largest compressor RLA . plus 100% of other RLA s
 Max Fuse Amp :225% of largest compressor RLA plus 100% of other RLA s.

Compressor Electrical and Mechanical Data

Model	RPM	Max RLA	LRA	Oil charge (Litr)
SM090-4	2900	12.1	98	3.25, Mineral-160p
SM120-4	2900	20.7	130	3.25, Mineral-160p
SM185-4	2900	29	175	6.2, Mineral-160p
SY240-4	2900	35.7	215	8, POE-320SZ
SY300-4	2900	49.3	270	8, POE-320SZ

RLA : Rated Load Amp.
 LRA : Locked Rotor Amp.(Starting Amp)

Dimensions:

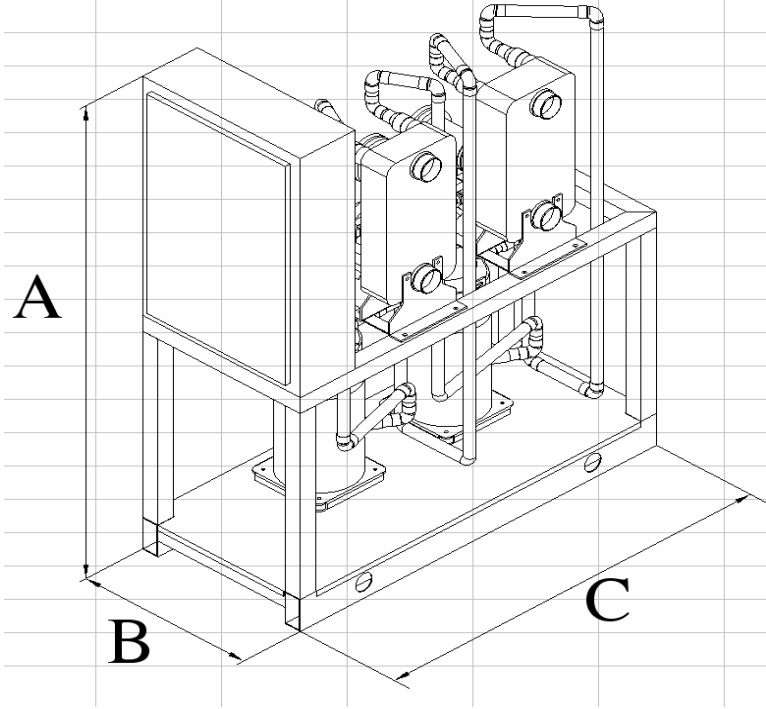

Model	ASPHLC	7.5-1	10-1	15-1	20-1	25-1	15-2	20-2	25-2	35-2
Height(A)		1460	1460	1460	1460	1460	1460	1460	1460	1460
Width(B)		620	620	620	620	620	620	620	620	620
Depth(C)		1300	1300	1300	1300	1300	1400	1400	1400	1400

Model	ASPHLC	40-2	45-2	50-2	60-4	70-4	80-4	90-4	100-4
Height(A)		1460	1460	1460	1460	1460	1460	1460	1460
Width(B)		620	620	620	800	800	800	800	800
Depth(C)		1500	1500	1500	2000	2000	2000	2000	2000